

# ALUMINIUM GANTRY CRANE, stationary model

## load capacity 1.500 kg with double beam

# SCHILLING

we lift it

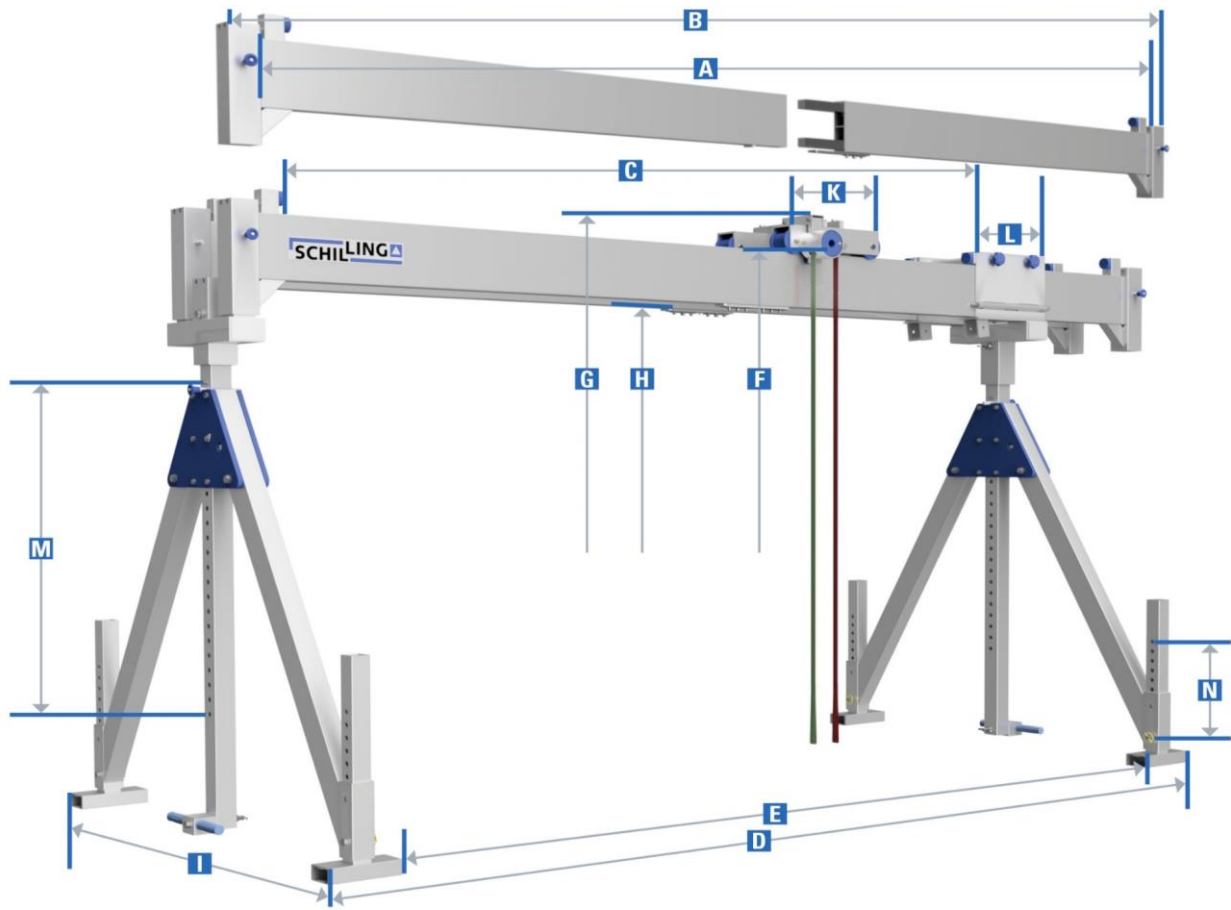

item no.	load capacity	beam length			total width of the crane		suspension point at the bolt of the trolley		total height		lower edge alu beam		lateral stand	park-brake trolley	horizontal adjuster	adjustment range		weight
		clear width	total	usable	outside	inside	min.	max.	min.	max.	min.	max.	width	width	width	beam support	adjustment foot	
	kg	A	B	C	D	E	F		G		H		I	K	L	M	N	kg

### SMALL

1511540-10	1500	4000	4016	3158	4141	3650	1834	2884	1934	2984	1567	2617	1293	480	421	650	400	244
1511550-10	1500	5000	5016	4158	5141	4650	1834	2884	1934	2984	1567	2617	1293	480	421	650	400	262
1511560-10	1500	6000	6016	5158	6141	5650	1834	2884	1934	2984	1567	2617	1293	480	421	650	400	279
1511570-10	1500	7000	7016	6158	7141	6650	1834	2884	1934	2984	1567	2617	1293	480	421	650	400	297
1511580-10	1500	8000	8016	7158	8141	7650	1834	2884	1934	2984	1567	2617	1293	480	421	650	400	314

### MEDIUM

1521540-10	1500	4000	4016	3158	4141	3650	2245	3395	2345	3495	1978	3128	1716	480	421	750	400	262
1521550-10	1500	5000	5016	4158	5141	4650	2245	3395	2345	3495	1978	3128	1716	480	421	750	400	280
1521560-10	1500	6000	6016	5158	6141	5650	2245	3395	2345	3495	1978	3128	1716	480	421	750	400	297
1521570-10	1500	7000	7016	6158	7141	6650	2245	3395	2345	3495	1978	3128	1716	480	421	750	400	315
1521580-10	1500	8000	8016	7158	8141	7650	2245	3395	2345	3495	1978	3128	1716	480	421	750	400	332

### HIGH

1531540-10	1500	4000	4016	3158	4141	3650	2787	4337	2887	4437	2520	4070	2214	480	421	1150	400	285
1531550-10	1500	5000	5016	4158	5141	4650	2787	4337	2887	4437	2520	4070	2214	480	421	1150	400	303
1531560-10	1500	6000	6016	5158	6141	5650	2787	4337	2887	4437	2520	4070	2214	480	421	1150	400	320
1531570-10	1500	7000	7016	6158	7141	6650	2787	4337	2887	4437	2520	4070	2214	480	421	1150	400	337
1531580-10	1500	8000	8016	7158	8141	7650	2787	4337	2887	4437	2520	4070	2214	480	421	1150	400	355