

# ALUMINIUM GANTRY CRANE

GB

Example documentation



## USER INFORMATION

The assembly, operating and maintenance instructions for SCHILLING products must be observed at all times. Users and/or their personnel must read the instructions thoroughly and understand them fully before using the product.

Please retain this user information for future reference!





## Contents

<b>1. INTRODUCTION .....</b>	<b>1</b>
1.1 MANUFACTURER.....	1
1.2 TERMS AND CONDITIONS .....	1
<b>2. PRESENTATION OF INFORMATION .....</b>	<b>2</b>
2.1 SYMBOLS AND TERMINOLOGY .....	2
2.2 INSTRUCTIONS FOR USE AND ENUMERATIONS.....	2
<b>3. DECLARATION OF CONFORMITY.....</b>	<b>3</b>
<b>4. SAFETY .....</b>	<b>4</b>
4.1 GENERAL SAFETY NOTES .....	4
4.2 APPROVED USE .....	5
4.3 NON APPROVED USE .....	5
<b>5. TECHNICAL DATA.....</b>	<b>6</b>
<b>6. GENERAL DATA .....</b>	<b>7</b>
<b>7. DELIVERY AND TRANSPORT .....</b>	<b>8</b>
7.1 SCOPE OF DELIVERY.....	8
7.2 TRANSPORTATION .....	8
7.3 STORAGE .....	8
<b>8. OVERVIEW OF INDIVIDUAL COMPONENTS OF THE ALUMINIUM GANTRY CRANE .....</b>	<b>9</b>
<b>9. ASSEMBLY .....</b>	<b>10</b>
<b>10. PUTTING INTO OPERATION .....</b>	<b>21</b>
10.1 COMPULSORY PRIOR INSPECTION AND TESTING .....	21
10.2 VISUAL INSPECTION, FUNCTION TEST .....	21
<b>11. OPERATION .....</b>	<b>22</b>
<b>12. MAINTENANCE.....</b>	<b>23</b>
12.1 MAINTENANCE PLAN.....	23
12.2 VISUAL INSPECTION, FUNCTION TESTING AND STRESS TESTING .....	23
12.3 INSPECTION REPORT / REPEAT INSPECTION .....	24
<b>13. DISASSEMBLY AND DISPOSAL .....</b>	<b>27</b>
13.1 DISASSEMBLY .....	27
13.2 DISPOSAL .....	27
13.3 DISPOSAL OF PACKAGING MATERIAL .....	27
<b>14. SERVICE.....</b>	<b>28</b>
14.1 CONTACT.....	28
14.2 SPARE PARTS ORDERING OR REORDERING PROCESS.....	28

## 1. Introduction

- ▲ The Aluminium Gantry Crane is used for lifting, lowering and moving loads with a trolley. The Aluminium Gantry Crane is only permitted to be used on flat and solid surfaces.
- ▲ This user information constitutes an integral part of the product and an element of the overriding risk assessment and handling instructions to be taken into account whenever lifting or handling loads.
- ▲ The user information must be available to all users.
- ▲ Please read this user information thoroughly before using the Aluminium Gantry Crane.
- ▲ This user information explains how to safely assemble, operate, maintain, repair, disassemble and dispose of the Aluminium Gantry Crane.
- ▲ In addition to this user information, you must also observe and comply with all applicable occupational health and safety regulations of the country and the environment in which the Aluminium Gantry Crane is used as well as all other general regulations and rules regarding safe and appropriate use.
- ▲ Images and illustrations in this user information may differ from the actual product which will be supplied.
- ▲ Unauthorized modifications of the Aluminium Gantry Crane or self-made auxiliary equipment are prohibited.

### 1.1 Manufacturer



### 1.2 Terms and Conditions

- ▲ In the event of direct sales transactions, the General Terms and Conditions can be obtained from the manufacturer or from their website.
- ▲ If you have purchased your device from an intermediary, please ask your distributor/salesperson.

## 2. Presentation of information

This user information uses symbols, terminology, instructions for use and enumerations as described in Chapters 2.1 to 2.2 below.

### 2.1 Symbols and terminology

#### Safety notes

Safety notes are categorised and presented as follows:

#### HAZARD

A safety note designated as a “HAZARD” indicates a risk which will directly and with certainty lead to death or severe, permanent personal injury.

#### WARNING

A safety note designated as a “WARNING” indicates a risk which may lead to severe personal injury or death.

#### CAUTION

A safety note designated as a “CAUTION” indicates a risk which may lead to minor to moderate personal injury.

#### NOTE

A safety note designated as a “NOTE” indicates a risk which may lead to material damage.

#### Useful information and tips



#### INFO

This symbol indicates useful information and tips.

#### Disposal



#### INFORMATION FOR DISPOSAL

of packaging materials, lifting devices, etc.

### 2.2 Instructions for use and enumerations

All instructions for use are presented in chronological order and numbered, e.g.:

1. Step 1

2. Step 2

Outcomes of actions are indicated by an arrow:

➤ Outcome or device response

Instructions for use which do not have to be carried out in a particular sequence are indicated as follows:

- Step
- Step

Outcomes of actions are indicated by an arrow:

➤ Outcome or device response

Enumerations are indicated by indents:

- Enumeration

### 3. Declaration of Conformity

#### EC Declaration of Conformity

#### **Pursuant to the EC Machinery Directive 2006/42/EC, Appendix II A**

We hereby declare that the below mentioned machine complies with the general health and safety requirements of EC Directive 2006/42/EC in terms of its design and construction and in the version marketed by us.

This declaration shall become invalid in the event of modifications to the machine without our prior approval.

#### **Manufacturer:**



#### **Description and identification of the machine:**

- Function: Aluminium Gantry Crane with trolley for lifting of loads, 1000 kg - 1500 kg, in combination with an optional suspension device.
  - Type/Model: Aluminium Gantry Crane, movable under load, small, medium, high
  - Item number: 1471040, 1471540  
1481040, 1481540  
1491040, 1491540
- \* for separable/pluggable beam versions additionally -10 (e.g. 1471040-10)  
\* for non standard beam lengths the last 2 digits are variable (e.g. 1471035 for beam length 3500 mm)

- Serial number: **Example documentation**

- Year of manufacture: 2023

#### **Applied harmonised standards, in particular:**

- DIN EN 13001-1:2015-06 – Cranes – General design – Part 1: General principles and requirements
- DIN EN 13001-2:2014-12 – Cranes – General design – T2 Load actions
- DIN EN 15011:2014-09 – Cranes – Bridge and Gantry Cranes
- DIN EN 1999-1-1:2014-03 – Design of aluminium structures – General structural rules

#### **Applied national standards and technical specifications, in particular:**

- DGUV Vorschrift (regulations) 52 (BGV D6) – UVV Krane (Cranes)

#### **Manufacturer:**

SCHILLING Kran- und Hebeteknik GmbH, Ernst-Zimmermann-Strasse 9-11, 88045 Friedrichshafen, Germany

#### **Signature:**

Martin Schilling – Managing Director

**Date:** 02.01.2023

#### **Authorized person for documentation:**

Danny Büdinger – Technician

SCHILLING Kran- und Hebeteknik GmbH, Ernst-Zimmermann-Strasse 9-11, 88045 Friedrichshafen, Germany

#### **UK Declaration of Conformity**

**Supply of Machinery (Safety) Regulations 2008: Great Britain**

## 4. Safety

Please read the safety instructions below thoroughly before putting the product into operation.

Chapters 4.1 to 4.3 set out general rules of conduct to be adhered to when handling the product. Instructions in the following chapters highlighted with a  symbol must be followed in order to avoid putting persons and materials at risk. Safety notes pertaining to individual instructions for use are listed before the relevant step and must be observed.

### 4.1 General safety notes

- Read this user information in full.
- Observe the safety notes.
- Ensure that this user information is available at the site of operation at all times.
- The product must be operated by suitably qualified personnel (see Tab. 1) only.
- In addition to this user information, you must also observe and comply with all applicable occupational health and safety regulations of the relevant country and environment in which the product is used, as well as other general regulations for safe and appropriate use.
- Any damage compromising safety must be repaired immediately.
- Perform all work prudently.
- Never open a lifting device when loaded.
- Never stand/walk below the suspended load.

#### Qualifications required for handling lifting devices

<i>Field of activity</i>	<i>Qualification</i>	<i>Specialist knowledge</i>
<i>Delivery and transport</i>	<i>Dealer, freight carrier</i>	<ul style="list-style-type: none"> <li>– Evidence of load safety induction</li> <li>– Safe handling of lifting devices</li> </ul>
<i>Storage</i>	<i>Warehouse staff</i>	<ul style="list-style-type: none"> <li>– Safe handling of lifting devices</li> </ul>
<i>Assembly, commissioning, maintenance, repair and disassembly</i>	<i>Qualified personnel</i>	<ul style="list-style-type: none"> <li>– Expert: technical training and expertise, sufficient knowledge about lifting devices</li> <li>– Safe handling of lifting devices</li> <li>– Product-specific knowledge</li> </ul>
<i>Operation, simple visual inspection</i>	<i>Qualified personnel</i>	<ul style="list-style-type: none"> <li>– Safe handling of lifting devices, technical training and expertise</li> </ul>
<i>Disposal</i>	<i>Qualified personnel</i>	<ul style="list-style-type: none"> <li>– Knowledge about the regulations for correct disposal and recycling</li> </ul>

Tab. 1: Overview

## 4.2 Approved use

- The lifting, lowering and moving loads with a trolley. The Aluminium Gantry Crane is only permitted to be used on flat and solid surfaces
- The stated load capacity must be observed
- Temperature ranges from -20° to +50°C
- Wind speeds of up to < 40 km/h
- When using the gantry crane, make sure that the beam length between the side frames is always at least 1.6 times the beam length outside the side frames.

## 4.3 Non approved use

- Exceeding the maximum load capacity
- Structural modifications of the product
- Standing/walking below the suspended load
- Pulling a load diagonally
- Forcefully freeing loads that are stuck
- Dragging loads along the ground
- Transporting persons and animals

No guarantee is provided for the completeness of Chapter 4.3.

Anything that is not explicitly permitted is classified as non approved use.

## 5. Technical data

<b>Item number „Version small“</b>	<b>1471040</b>	<b>1471540</b>
Load capacity	1000 kg	1500 kg
Beam length	4000 mm	4000 mm
<b>Item number „Version medium“</b>	<b>1481040</b>	<b>1481540</b>
Load capacity	1000 kg	1500 kg
Beam length	4000 mm	4000 mm
<b>Item number „Version high“</b>	<b>1491040</b>	<b>1491540</b>
Load capacity	1000 kg	1500 kg
Beam length	4000 mm	4000 mm

### Notes:

In the case of separable/pluggable beam versions ( xxxxxx-10) and non standard beam lengths (e.g. xxxxx35) see the corresponding delivery note and crane engraving for the total weight.

## 6. General data

The following data is engraved on the individual components of the Aluminium Gantry Crane:

A: Load capacity  
C: Type  
E: Serial number

B: Year of manufacture  
D: Total weight

Example of a SCHILLING engraving:

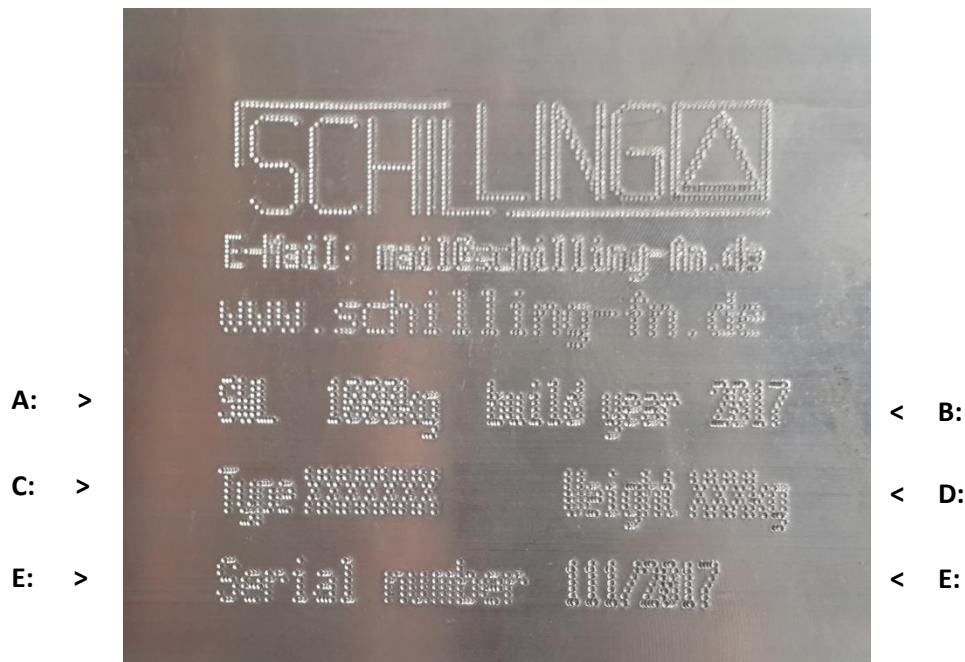

## 7. Delivery and transport

### 7.1 Scope of delivery

Immediately check the delivery for completeness against the enclosed delivery note. You may also use the overview of the product and the parts list in order to verify the completeness of the delivery (see Chapter 8).

If parts are missing, please contact your supplier immediately.

If notified late, especially if the product has already been used, we cannot accept any claims for after supply.

### 7.2 Transportation

The product is checked and adequately packaged prior to delivery.

#### NOTE

##### Damage to the device

Incorrect transportation may damage the product.

- Always transport the product as intended.
- Use a suitable means of transport.
- Make sure that the product is adequately secured during transportation.

### 7.3 Storage

#### NOTE

##### Damage to the device

Incorrect storage may damage the product.

- Always store the product as intended.
- Store the product in a clean and dry place.
- Protect the product from:
  - constant humidity or outdoor storage
  - contamination
  - damage
  - corrosion

## 8. Overview of individual components of the Aluminium Gantry Crane

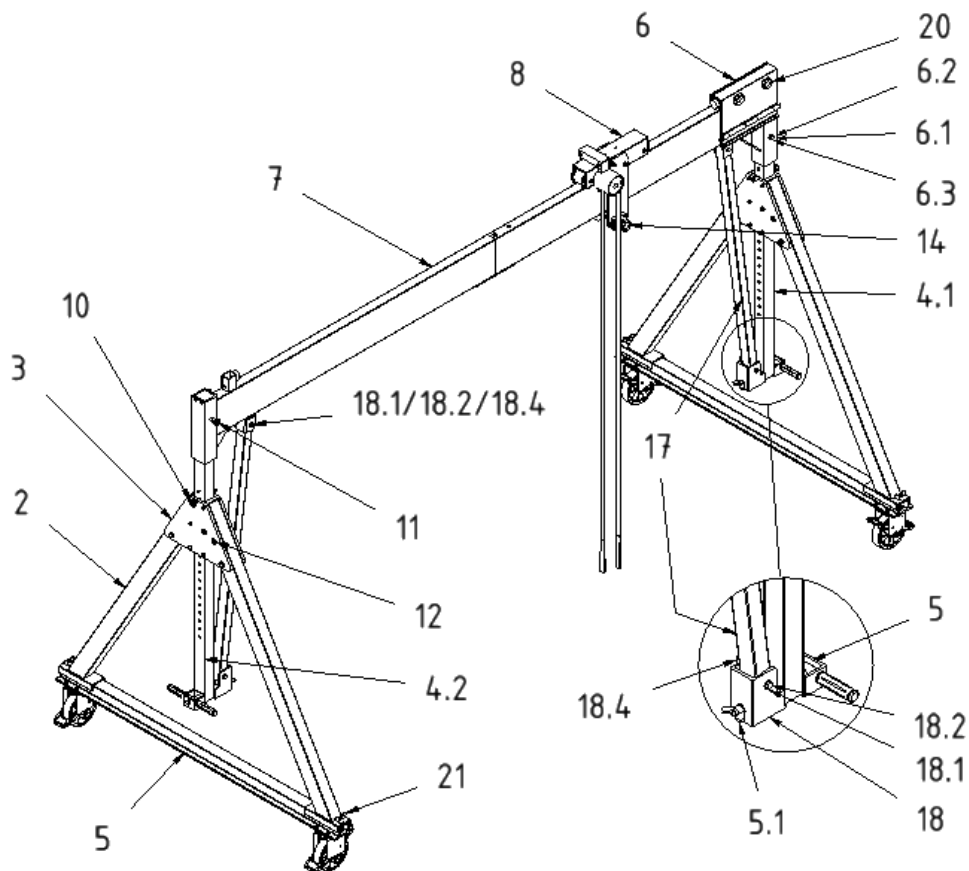

### Parts List:

Item	Name	Quantity	Item	Name	Quantity
2	Stand brace	4	10	Bolt (unlosable), D16, for beam support	2
3	Plastic plates (trapezium)	2	11	Bolt (unlosable), D16, for aluminium beam	1
4.1	Beam support "short"	1	12	Push bolt	4
4.2	Beam support "long"	1	14	Suspension bolt (unlosable), for trolley	1
5	Lifting handle	2	17	Brace	2
5.1	Wing nut, M16	2	18	Brace holder - beam support	2
6	Horizontal adjuster	1	18.1	Bolt, M12x100	4
6.1	Bolt, M16x130	1	18.2	Washer, M12	8
6.2	Washer, M16	2	18.4	Wing nut, M12	4
6.3	Wing nut, M16	1	19	Wheel set	2
7	Aluminium beam	1	20	Star knob screw	2
8	Park brake trolley	1	21	Wing nut, M16	4

For separable/pluggable beam versions, an additional assembly instruction is attached in Chapter 9.

## 9. Assembly

### ⚠ CAUTION

The Aluminium Gantry Crane has pinching points which may cause injuries.

- Perform all assembly work prudently and cautiously.



#### INFO

#### Recommended personnel, tools and aids for assembling the Aluminium Gantry Crane:

- At least 2 people
- Socket or open-end wrench (*if necessary*)
- Step ladder or similar (*if necessary*)

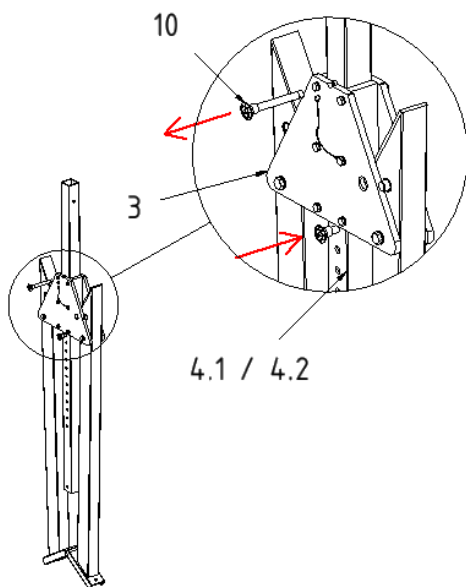

#### 1. Repositioning of the bolts for beam support:

##### 1.1.

Insert both bolts for beam support (10) underneath the plastic plates (trapezium) (3) into the beam supports (4.1/4.2).

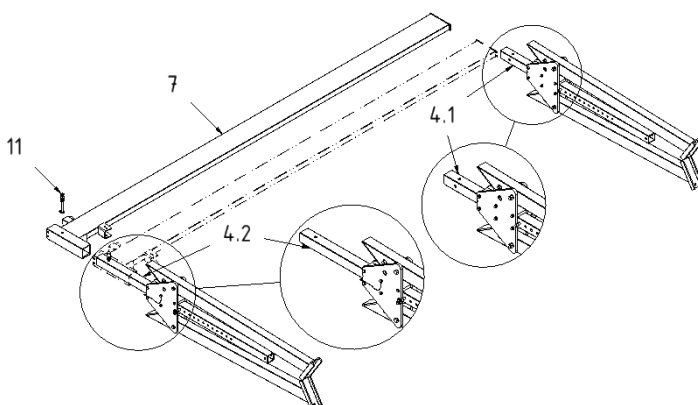

#### 2. Aluminium beam attachment:

##### 2.1.

Lay the 2 still folded lateral stands upright on a flat and solid surface.

(Bolt head on the trapezium outwards / nut inwards.)

##### 2.2.

Slide the beam housing (*aluminium square profile*), found welded on the end of the beam (7), onto the longer beam support (4.2).

##### 2.3.

Insert the bolt (11) into the hole in the beam housing of the beam (7) to secure the beam.

**CAUTION**

The Aluminium Gantry Crane has pinching points which may cause injuries.

- Perform all assembly work prudently and cautiously.

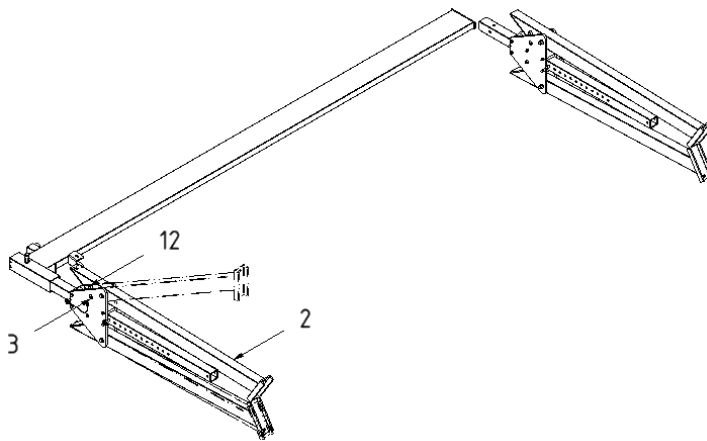

**3. Partly unfold the first lateral stand:**

**3.1.**

Push in the pressure pin (12) on the upper stand brace (2) of the lateral stand.

**3.2.**

Fold the stand brace (2) outwards (*upwards*) until the push bolt clicks and locks into the hole of the plastic plate (3).

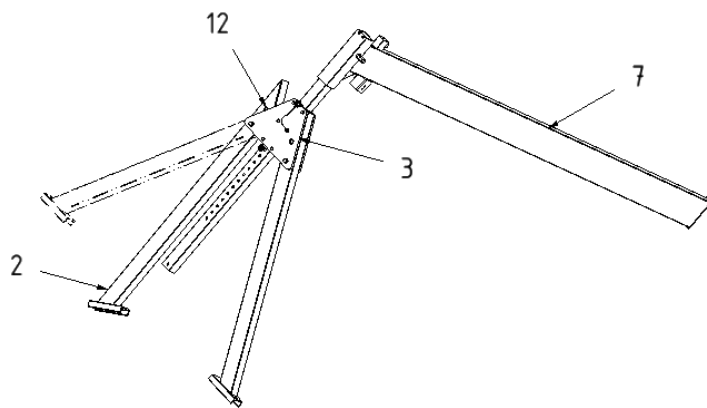

**4. Erecting and completely unfolding the first lateral stand:**

**4.1.**

Tilt sideways the entire lateral stand including beam (7) until the lateral stand is erect.

**4.2.**

Tilt slightly the lateral stand, so that the foot of the still folded stand brace (2) is free and can be easily unfolded.

**4.3.**

Push in the push bolt (12) on the stand brace (2) of the lateral stand.

**4.4.**

Fold the stand brace (2) outwards until the push bolt clicks and locks into the hole of the plastic plate (3).

**⚠CAUTION**

The Aluminium Gantry Crane has pinching points which may cause injuries.

- Perform all assembly work prudently and cautiously.

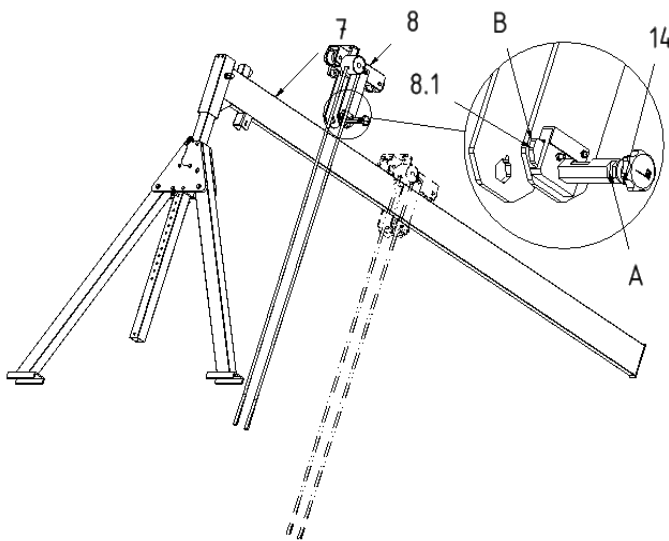

**5. Placing the trolley onto the beam:**

**5.1.**

Place the trolley (8) onto the beam (7) by pressing the locking mechanism (8.1) upwards and pulling out the suspension bolt (14).

**5.2.**

After positioning the trolley (8) on the beam, re-insert the suspension bolt (14) into the hexagonal hole.

**5.3.**

Ensure that after the re-insertion of the suspension bolt (14) that the locking mechanism (8.1) has snapped shut on the bolt groove (A).

**5.4.**

When the locking mechanism (8.1) has locked on the bolt groove (A) the safety hole (B) can be seen.

**5.5.**

Secure the trolley (8) against unwanted rolling by pulling firmly on the red band.

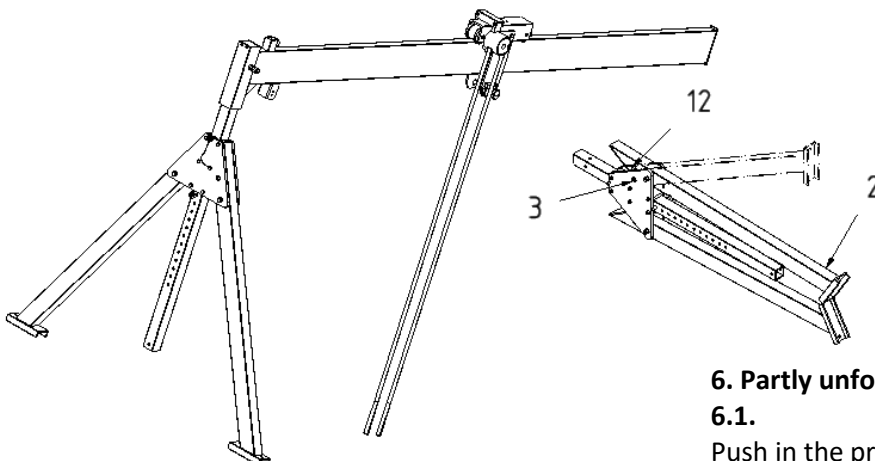

**6. Partly unfold the second lateral stand:**

**6.1.**

Push in the pressure pin (12) on the upper stand brace (2) of the lateral stand.

**6.2.**

Fold the stand brace (2) outwards (*upwards*) until the push bolt clicks and locks into the hole of the plastic plate (3).

**⚠CAUTION**

The Aluminium Gantry Crane has pinching points which may cause injuries.

- Perform all assembly work prudently and cautiously.

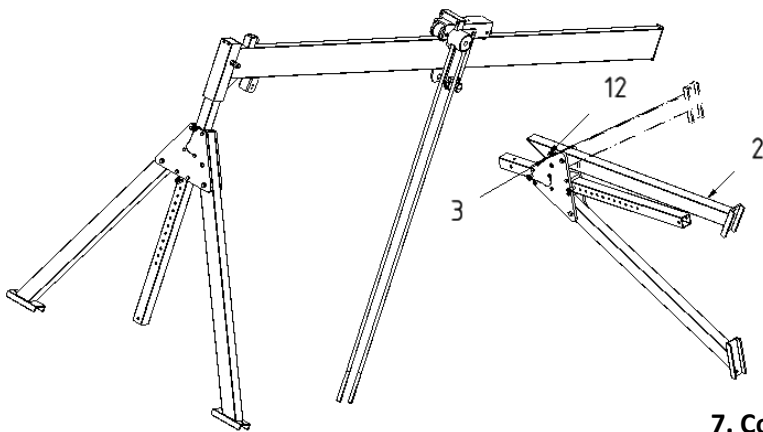

**7. Completely unfolding the second lateral stand:**

**7.1.**

Rotate the lateral stand 180 degrees.

**7.2.**

Push in the push bolt (12) on the upper stand brace (2) of the lateral stand.

**7.3.**

Fold the stand brace (2) outwards (upwards) until the push bolt clicks and locks into the hole of the plastic plate (3).

**⚠CAUTION**

The Aluminium Gantry Crane has pinching points which may cause injuries.

- Perform all assembly work prudently and cautiously.



**INFO on assembly step 8**

**Lateral stands with manual winch (if ordered):**

- When the lateral stands are erected the winches must face outwards.

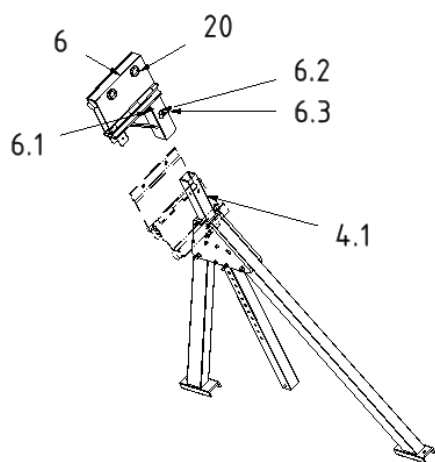

**8. Attaching the horizontal adjuster:**

**8.1.**

Erect the lateral stand and tilt it slightly.

**8.2.**

Slide the horizontal adjuster (6) onto the shorter beam support (4.1) of the lateral stand (*bump stop facing inwards*).

**8.3.**

Secure the horizontal adjuster (6) onto the beam support (4) using bolts (6.1), two washers (6.2) and nut (6.3).

**8.4.**

Open the horizontal adjuster (6) using the blue star knobs (20).

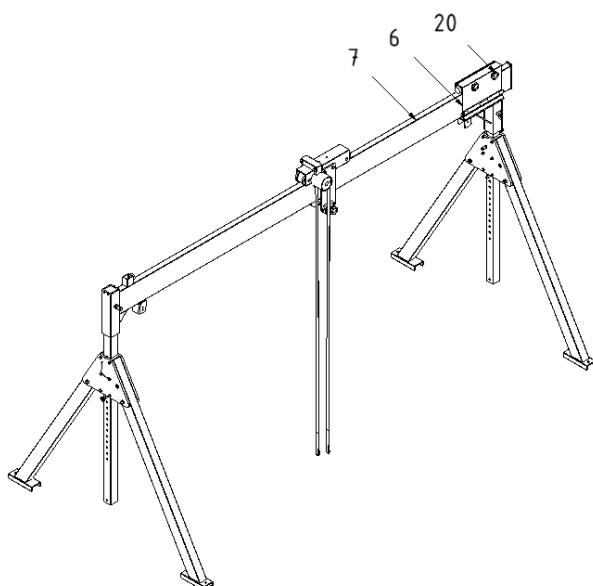

**9. Erection of the Aluminium Gantry Crane:**

**9.1.**

Erect the second lateral stand (*one person*).

**9.2.**

Lift the free end of the beam (7) (*another person*) and step, if needed, onto e.g. a step ladder.

**9.3.**

Lay the end of the beam (7) into the lower part of the already open horizontal adjuster (6).

**9.4.**

Close the lid of the horizontal adjuster (6). Securely clamp the beam (7) in the horizontal adjuster (6) by tightening the blue star knobs (20).

**CAUTION**

The Aluminium Gantry Crane has pinching points which may cause injuries.

- Perform all assembly work prudently and cautiously.



**INFO on assembly step 10**

**Lateral stands with manual winch (if ordered):**

- No lifting handle (5) as described in step 10.2. is mounted on this version.
- Consequently, lift the crane using the rope attachment point.
- Then complete the steps 10.4. and 10.5.

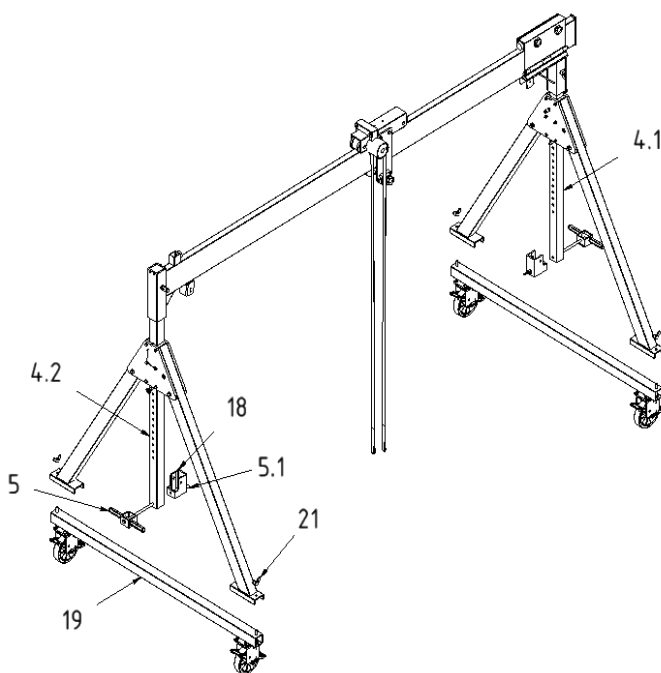

**10. Mounting the wheel set:**

**10.1.**

Before mounting the wheel set (19) onto the lateral stand, ensure that the brakes of both wheel sets (19) are applied.

*(The wheel brake is activated via a locking latch.)*

**10.2.**

Attach in the long beam support (4.2) a brace holder (18) in combination with a lifting handle (5) into the lowest drilled hole and secure this with a wing nut (5.1).

**10.3.**

Using the lifting handle (5), lift the lateral stand *(one person)*.

**10.4.**

Place the lateral stand onto the bolts of the wheel set (19) *(another person)*.

**10.5.**

Secure the wheel set (19) per hand using 2 wing nuts (21).

**10.6.**

For the second wheel set (19) repeat for the short beam support (4.1) the steps 10.1.-10.5.

**⚠CAUTION**

The Aluminium Gantry Crane has pinching points which may cause injuries.

- Perform all assembly work prudently and cautiously.

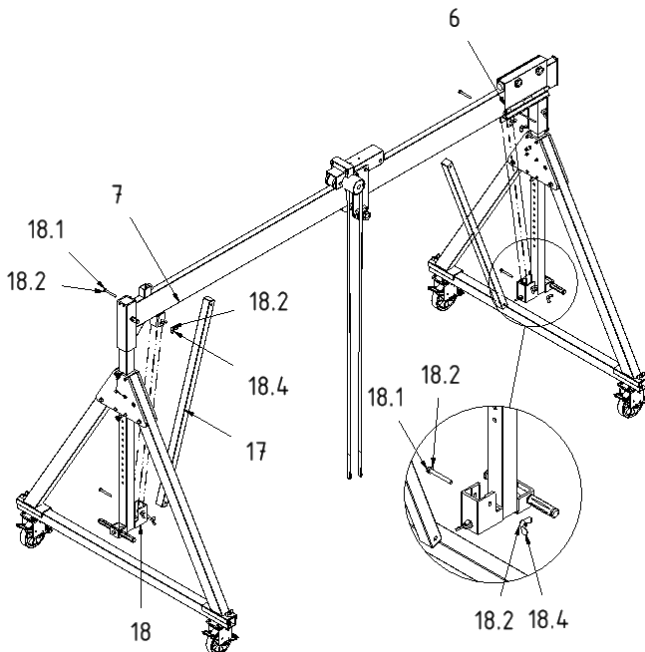

**11. Mounting the braces:**

**11.1.**

Bolt the first brace (17) on the lower end into the brace holder (18) using a bolt (18.1), 2 washers (18.2) and a wing nut (18.4).

**11.2.**

Bolt the first brace (17) on the upper end into the brace holder (18) using a bolt (18.1), 2 washers (18.2) and a wing nut (18.4). The upper brace holder is welded directly to the beam (7) or horizontal adjuster (6).

**11.3.**

For the second brace (17) repeat steps 11.1.-11.2.



**INFO on assembly step 12**

**Lateral stands with manual winch (if ordered):**

- Height adjustment of the beam supports (4.1/4.2) according to attached separate user manual.

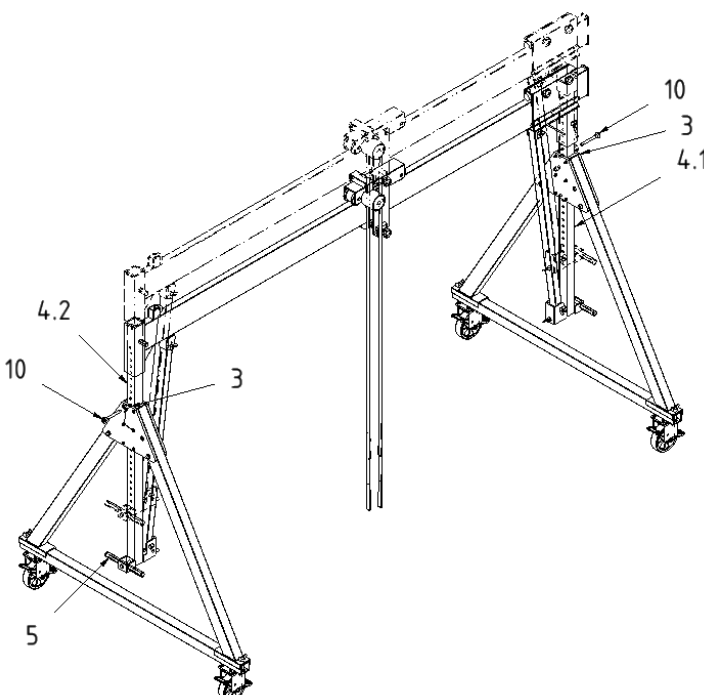

**12. Height adjustment of the Aluminium Gantry Crane:**

**12.1. (with lifting handles)**

Pull out the 2 bolts (10) from the beam supports (4.1/4.2). Simultaneously lift the 2 beam supports (4.1/4.2) with the lifting handles (5) and secure the required height with the bolts (10).

*(Pay attention after inserting the bolts (10) that only the steel portion of the bolt lays in the groove of the plastic plates (3) and not on the plastic handle of the bolt.)*

**12.2. (with hand winches)**

Height adjustment is according to the attached separate user manual.

**Caution:**

Before applying load to the crane the bolts (10) must always lay correctly in the plastic plates (3) and the rope of the winch must not be under tension.



➤ **Now the Aluminium Gantry Crane is fully assembled.**

➤ **Disassemble in reverse order, taking care to either remove the trolley from the aluminium beams, or at least to engage its brake during disassembly.**

**Engage the brake to fix the trolley by pulling firmly on the red band.**

## Additional assembly instruction for separable/pluggable beam versions (if ordered)



**INFO**

Recommended personnel, tools and aids for assembling the separable/pluggable aluminium beam:

- M10 hexagonal socket wrench (allen key)

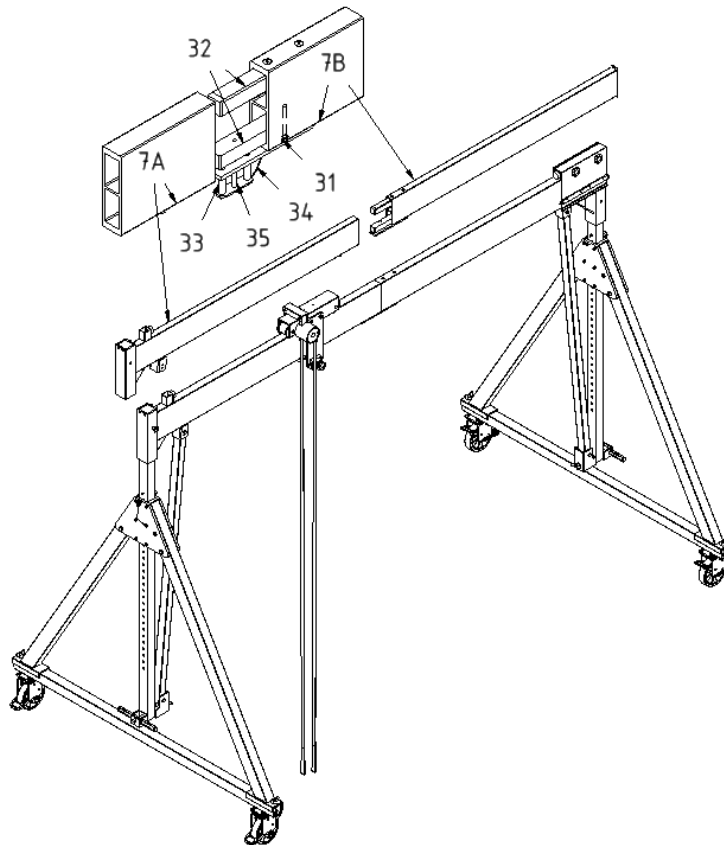

**Parts list:**

Item	Name	Number of pieces	Item	Name	Number of pieces
7A	Aluminium beam (part A)	1	33	Fixing element	1
7B	Aluminium beam (part B)	1	34	Securing rope	1
31	Socket bolt, M10	2	35	Socket bolt, M10	1

32	Connecting element	2
----	--------------------	---

The following instructions describe the assembly of separable/pluggable aluminium beams.

**Disassemble in reverse order.**

**Step 1:** Loosen the socket bolt (31) to loosen the bottom connecting element (32) so that you can more easily connect the aluminium beam (7B) with the aluminium beam (7A).

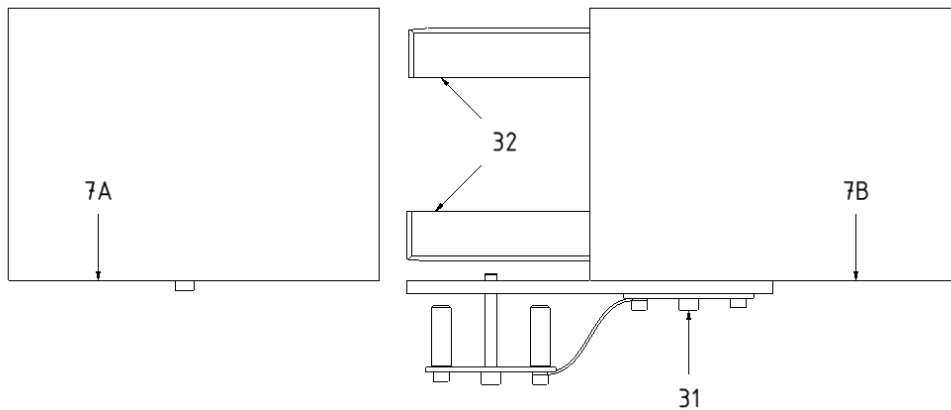

**Step 2:** Insert the connecting element (33), which is secured against loss by a securing rope (34), into the holes on aluminium beam (7A), and fix it with the socket bolt (35).

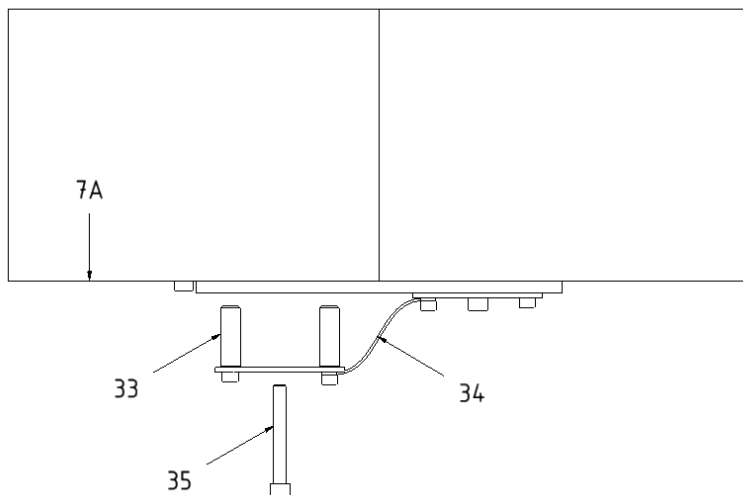

**Step 3:** Firmly tighten the socket bolts (31 + 35).

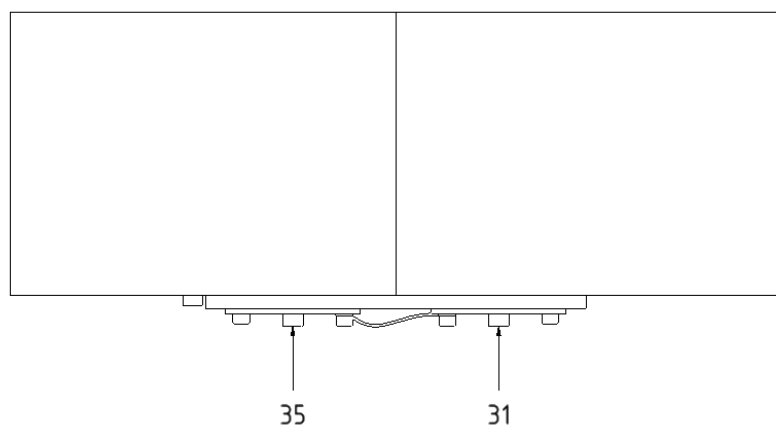

## 10. Putting into operation

### 10.1 Compulsory prior inspection and testing

Inspection and testing of the Aluminium Gantry Crane is required prior to commissioning in order to ensure that the Aluminium Gantry Crane has been fully and correctly assembled.

In addition, this ensures that the Aluminium Gantry Crane is in perfect working order and ready for its intended use.

#### **WARNING**

Without prior inspection and testing, injuries may occur during commissioning.  
Inspect and test the Aluminium Gantry Crane as follows:

- Visual inspection
- Function test

### 10.2 Visual inspection, function test

#### Visual inspection

The Aluminium Gantry Crane must be inspected every time before putting it back into operation.

#### **CAUTION**

The Aluminium Gantry Crane has pinching points which may cause injuries.

- Perform all inspections and testing of the Aluminium Gantry Crane prudently and cautiously.
1. The aluminium beams must be aligned horizontally.
  2. The beam supports of the lateral stands must be aligned vertically.
  3. Prior to loading the Aluminium Gantry Crane, all bolts must have been inserted and (if necessary) secured with clip pins.
  4. The push bolts must have snapped into the plastic (trapezoidal) plates.
  5. In particular, check load bearing parts for damage and broken weld seams.
  6. Terminate operation in the event of faults. Faults must be eliminated by qualified personnel.

#### Function test

The Aluminium Gantry Crane must be tested every time before putting it back into operation.

#### **WARNING**

Loads may fall in the event of deformation and wear of individual components.

- Take the Aluminium Gantry Crane out of operation immediately.
  - Have the device inspected and tested by a qualified expert.
1. Check that the brake on the trolley is functioning (green > open / red > closed).
  2. Verify to what extent the individual components are still functional.
  3. If in doubt, replace individual components.
  4. Verify that all movable parts are able to move freely.
  5. Replace parts which do not move freely.
  6. Put the Aluminium Gantry Crane out of operation if no longer functional or damaged beyond repair.
  7. Dispose of the individual material components (see Chapter 13).

## 11. Operation

The Aluminium Gantry Crane can be used as intended once it has been properly assembled and put into operation.

### CAUTION

The Aluminium Gantry Crane has pinching points which may cause injuries.

- Operate the Aluminium Gantry Crane prudently and carefully.

### WARNING

Various hazards may occur in connection with the Aluminium Gantry Crane.

- If the trolley brake is not engaged and the aluminium beam is at a slight incline, the trolley can move unexpectedly.
- If the Aluminium Gantry Crane is not operated as intended, injuries may occur when adjusting the beam supports.
- Select the distance between the two lateral stands so that the stability of the Aluminium Gantry Crane is ensured.
- If faults are identified at welded joints, a supporting part may break, causing the load to fall and potentially result in severe personal injury.

### DANGER

Never work below a load on the Aluminium Gantry Crane.

- Never stand/walk below the suspended load

The Aluminium Gantry Crane is used for lifting, lowering and moving loads with a trolley.

The Aluminium Gantry Crane is only permitted to be used on flat and solid surfaces.

## 12. Maintenance

The product is essentially maintenance free.

### 12.1 Maintenance plan

Maintenance date	Action
Prior to putting into operation	- Visual inspection and function testing by qualified personnel
Prior to each subsequent operation, after initial putting into operation without any prior extraordinary incidents	- Visual inspection by qualified personnel
Annually	- Visual inspection, function testing and stress test performed by a qualified expert

### 12.2 Visual inspection, function testing and stress testing

#### Visual inspection

See Chapter 10.2

#### Function testing

See Chapter 10.2

#### Stress testing according to the relevant guidelines

The product must be subjected to stress tests at least once a year, and immediately in the event of modifications or repairs.

#### **WARNING**

Operators of the product are required to comply with statutory regulations.

- Have the device professionally inspected by a qualified expert (see Chapter 12.3)

1. Operators of the product must ensure that the product is inspected by a qualified expert at least once a year and that any faults identified during these inspections are eliminated immediately.
2. (Where applicable) The guidelines of the DGUV Vorschrift (regulations) 52 (BGV D6) – UVV Krane (cranes), must be observed.

### 12.3 Inspection report / repeat inspection

Product: **Aluminium Gantry Crane, movable under load,  
with lateral stand, collapsible,  
incl. park-break trolley,  
incl. integrated horizontal adjuster.**

Manufacturer: SCHILLING Kran- und Hebetchnik GmbH, – [www.schilling-fn.de](http://www.schilling-fn.de)

Year of manufacture: 2023

Please check the engraving on the product for the item number, load capacity, serial number and net weight of the device.

- 1) Inspection prior to delivery.  
Visual inspection and function testing of the product and its components have been performed.  
The product has been developed, constructed and built in accordance with the rules of engineering.

Date: Date of dispatch (see delivery note)

Owner's/Manufacturer's signature

- 2) Repeat inspection  
Inspection has been performed

Date:

Signature of the qualified expert

- 3) Repeat inspection  
Inspection has been performed

Date:

Signature of the qualified expert

- 4) Note  
Inspection has been performed

Date:

Signature of the qualified expert

**Next inspection: 1 year after delivery (at the latest)**

**Product:** Aluminium Gantry Crane, movable under load,  
with lateral stand, collapsible,  
incl. park-break trolley,  
incl. integrated horizontal adjuster.

**Manufacturer:** SCHILLING Kran- und Hebeteknik GmbH, – [www.schilling-fn.de](http://www.schilling-fn.de)

**Year of manufacture:** 2023

Please check the engraving on the product for the item number, load capacity, serial number and net weight of the device.

Findings / drawing					
Known faults have been fixed by -us / -the company. Date and signature of the operations manager:					
There is -no- reason to object to continued operation. Re-inspection is -not- required. Date and inspector's signature:					
Acknowledged. Date and signature of the operations manager:					
Participants:	Yes	No	Inspection according to Art.	Yes	No
Rating plate:	Yes	No	Inspection badge:		
Last inspection:			Next inspection:		
Short statistics created:					

Remark	Inspector's name and company
Repeat inspection has been performed. – No´) – faults identified – see Inspection report´) Sheet no. _____	_____ (Date Signature)
Repeat inspection has been performed. – No´) – faults identified – see Inspection report´) Sheet no. _____	_____ (Date Signature)
Repeat inspection has been performed. – No´) – faults identified – see Inspection report´) Sheet no. _____	_____ (Date Signature)
Repeat inspection has been performed. – No´) – faults identified – see Inspection report´) Sheet no. _____	_____ (Date Signature)
Repeat inspection has been performed. – No´) – faults identified – see Inspection report´) Sheet no. _____	_____ (Date Signature)
Repeat inspection has been performed. – No´) – faults identified – see Inspection report´) Sheet no. _____	_____ (Date Signature)
´) please delete if not applicable	

## 13. Disassembly and Disposal

As manufacturers, we are required by law to inform you not to dispose of the product as unsorted waste. Dispose of it separately via collection and return points for industrial and commercial waste. The product must therefore be disassembled into its individual components.

### 13.1 Disassembly

**⚠ CAUTION**

Disassembly of the product on unstable surfaces or by means of unsuitable tools may result in injuries.

1. The assembled product is disassembled in the reverse order to that described in Chapter 9.
2. The individual assemblies of the product must then be disassembled by means of a suitable tool.

### 13.2 Disposal



**INFORMATION FOR DISPOSAL**

If the product is no longer functional or cannot be repaired, it must be disposed of in accordance with the applicable regulations.

The product consists of several different material components which must be disposed of separately:

1. Dispose of aluminium components as scrap aluminium.
2. Dispose of metal components as scrap metal.
3. Dispose of plastic components as scrap plastic.
4. Dispose of electrical components as electrical scrap (when using an electrical chain hoist).

### 13.3 Disposal of packaging material



**INFORMATION FOR DISPOSAL**

Packaging material must be correctly disposed of or recycled.

## 14. Service

### 14.1 Contact

For service matters or all other enquiries, please contact your supplier.

### 14.2 Spare parts ordering or reordering process



#### INFO

Please use the overview and table in Chapter 8 for better identification of the required component and submit this to your supplier.

1. Determine the serial number of your product. The serial number can be found in this user Information in Chapter 3. The serial number is also engraved on the product.
2. Determine the year of manufacture of the product. The year of manufacture can be found in this user information in Chapter 3. The year of manufacture is also engraved on the product.
3. Use the overview in Chapter 8 and highlight the component or assembly in question.
4. Then contact your supplier directly, submitting the collected data and any other details.