

ALUMINIUM GANTRY CRANE, movable under load

load capacity 500 kg, 1.000 kg, 1.500 kg with single beam

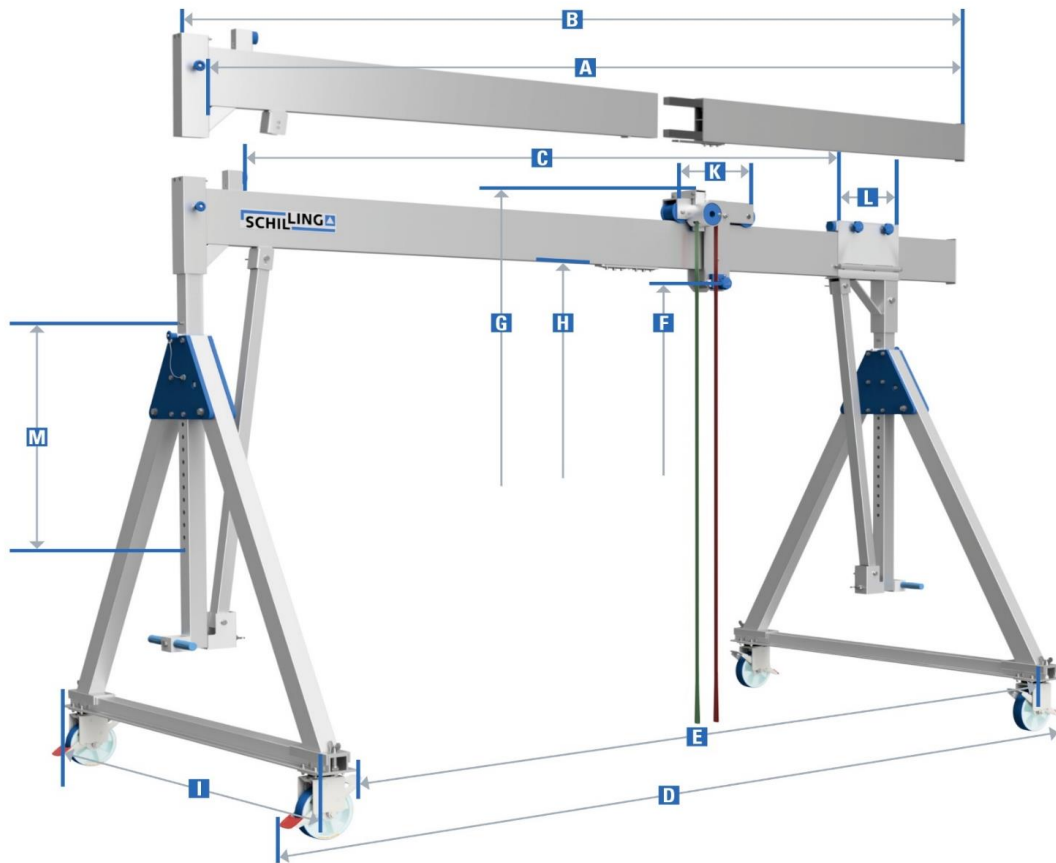

item no.	load capacity	beam length			total width of the crane		suspension point at the bolt of the trolley		total height		lower edge alu beam		lateral stand	park-brake trolley	horizontal adjuster	adjustment range	weight
		clear width	total	usable	outside	inside	min.	max.	min.	max.	min.	max.	width	width	width	beam support	
	kg	A	B	C	D	E	F		G		H		I	K	L	M	kg
SMALL																	
1470540-10	500	4000	4100	3399	4234	3849	1699	2099	2144	2544	1777	2177	1488	480	421	400	177
1471040-10	1000	4000	4100	3399	4234	3849	1699	2099	2144	2544	1777	2177	1488	480	421	400	184
1471540-10	1500	4000	4100	3399	4234	3849	1699	2099	2144	2544	1777	2177	1488	480	421	400	184
MEDIUM																	
1480540-10	500	4000	4100	3399	4234	3849	2137	2987	2582	3432	2215	3065	1988	480	421	850	203
1481040-10	1000	4000	4100	3399	4234	3849	2137	2987	2582	3432	2215	3065	1988	480	421	850	210
1481540-10	1500	4000	4100	3399	4234	3849	2137	2987	2582	3432	2215	3065	1988	480	421	850	210
HIGH																	
1490540-10	500	4000	4100	3399	4234	3849	2468	3768	2913	4213	2546	3846	2312	480	421	1300	222
1491040-10	1000	4000	4100	3399	4234	3849	2468	3768	2913	4213	2546	3846	2312	480	421	1300	229
1491540-10	1500	4000	4100	3399	4234	3849	2468	3768	2913	4213	2546	3846	2312	480	421	1300	229