

ALUMINIUM GANTRY CRANE, movable under load
load capacity 1.000 kg and 1.500 kg with double beam
beam length 4.000 mm

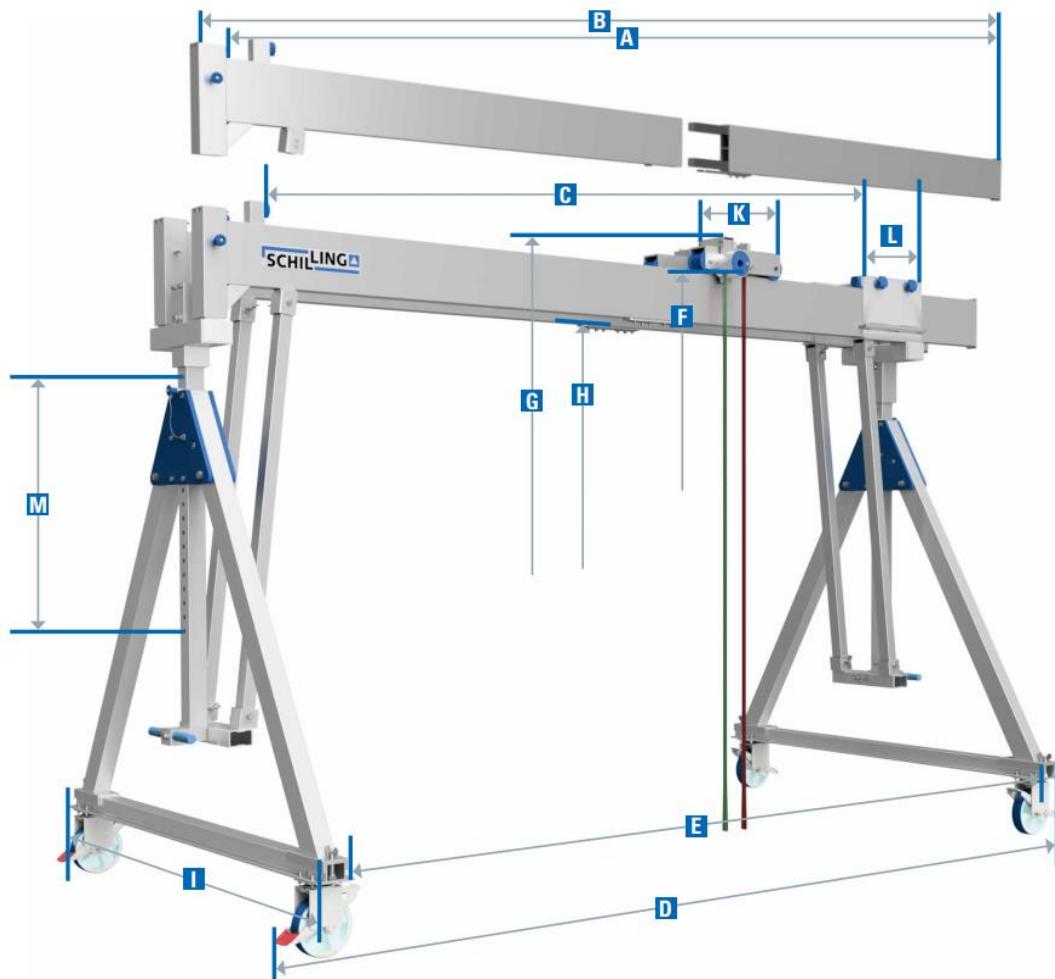

item no.	load capacity	beam length			total width of the crane		suspension point at the bolt of the trolley		total height		lower edge alu beam		lateral stand	park-brake trolley	horizontal adjuster	adjustment range	weight
		clear width	total	usable	outside	inside	min.	max.	min.	max.	min.	max.	width	width	width	beam support	
	kg	A	B	C	D	E	F		G		H		I	K	L	M	kg
		mm	mm	mm	mm	mm	mm	mm	mm	mm	mm	mm	mm	mm	mm	mm	mm
SMALL																	
14401040-10	1000	4000	4016	3158	4141	3746	2055	2405	2155	2505	1788	2138	1488	480	421	350	290
14401540-10	1500	4000	4016	3158	4141	3746	2055	2405	2155	2505	1788	2138	1488	480	421	350	290
MEDIUM																	
14501040-10	1000	4000	4016	3158	4141	3746	2533	3283	2633	3383	2266	3016	1988	480	421	750	322
14501540-10	1500	4000	4016	3158	4141	3746	2533	3283	2633	3383	2266	3016	1988	480	421	750	322
HIGH																	
14601040-10	1000	4000	4016	3158	4141	3746	2924	4074	3024	4174	2657	3807	2312	480	421	1150	349
14601540-10	1500	4000	4016	3158	4141	3746	2924	4074	3024	4174	2657	3807	2312	480	421	1150	349

ALUMINIUM GANTRY CRANE, movable under load
load capacity 1.500 kg with double beam
beam length 5.000 - 8.000 mm

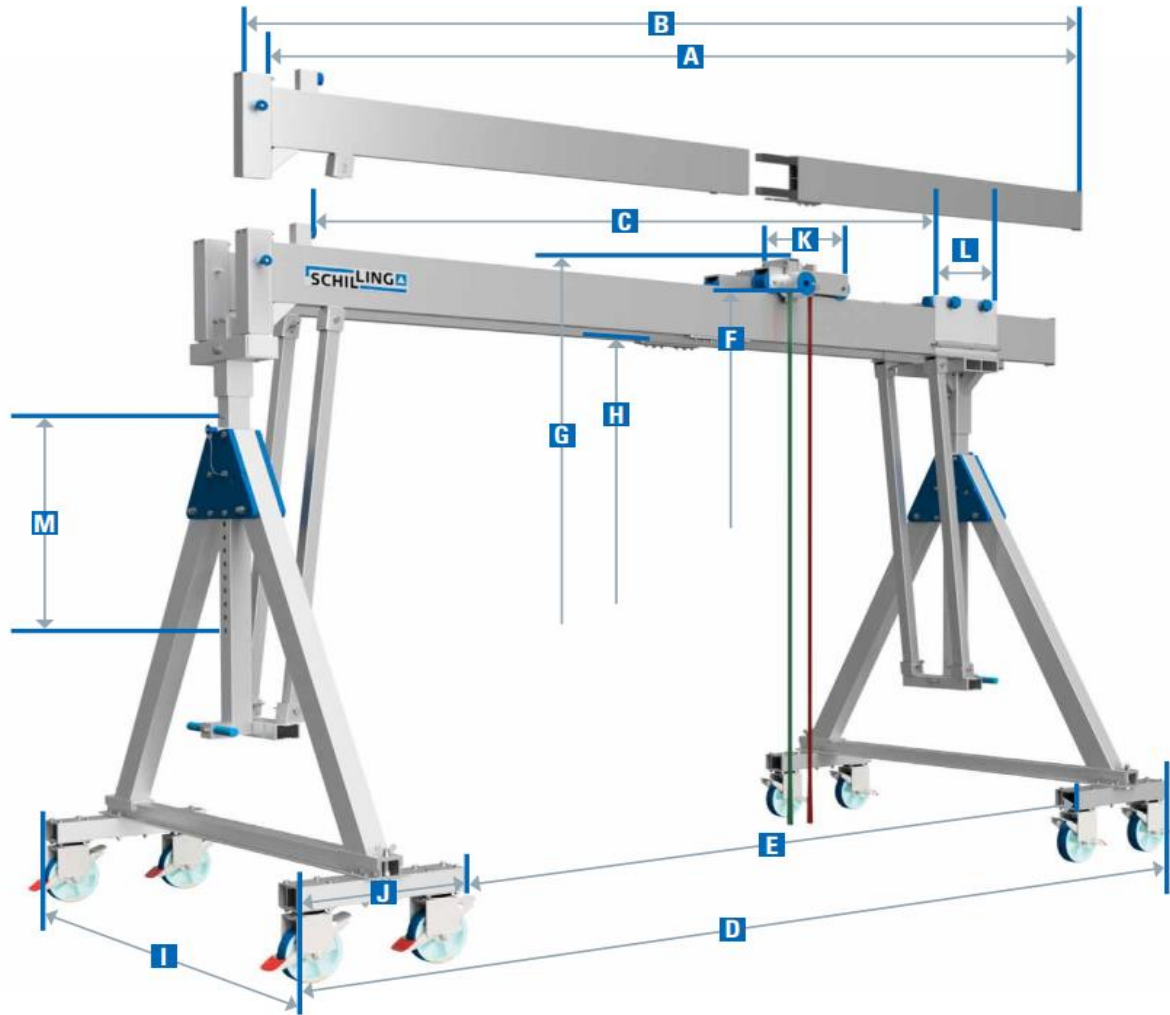

item no.	load capacity	beam length			total width of the crane		suspension point at the bolt of the trolley		total height		lower edge alu beam		lateral stand		park-brake trolley	horizontal adjuster	adjustment range	weight
		clear width	total	usable	outside	inside	min.	max.	min.	max.	min.	max.	width	depth				
	kg	A	B	C	D	E	F	G	H	I	J	K	L	M				kg
SMALL																		
14401550-10	1500	5000	5016	4158	5482	4290	2135	2485	2235	2585	1868	2218	1488	596	480	421	350	350
14401560-10	1500	6000	6016	5158	6482	5290	2135	2485	2235	2585	1868	2218	1488	596	480	421	350	368
14401570-10	1500	7000	7016	6158	7482	6290	2135	2485	2235	2585	1868	2218	1488	596	480	421	350	385
14401580-10	1500	8000	8016	7158	8482	7290	2135	2485	2235	2585	1868	2218	1488	596	480	421	350	403
MEDIUM																		
14501550-10	1500	5000	5016	4158	5482	4290	2613	3363	2713	3463	2346	3096	1988	596	480	421	750	383
14501560-10	1500	6000	6016	5158	6482	5290	2613	3363	2713	3463	2346	3096	1988	596	480	421	750	401
14501570-10	1500	7000	7016	6158	7482	6290	2613	3363	2713	3463	2346	3096	1988	596	480	421	750	418
14501580-10	1500	8000	8016	7158	8482	7290	2613	3363	2713	3463	2346	3096	1988	596	480	421	750	435
HIGH																		
14601550-10	1500	5000	5016	4158	5482	4290	3004	4154	3104	4254	2737	3887	2312	596	480	421	1150	409
14601560-10	1500	6000	6016	5158	6482	5290	3004	4154	3104	4254	2737	3887	2312	596	480	421	1150	427
14601570-10	1500	7000	7016	6158	7482	6290	3004	4154	3104	4254	2737	3887	2312	596	480	421	1150	444
14601580-10	1500	8000	8016	7158	8482	7290	3004	4154	3104	4254	2737	3887	2312	596	480	421	1150	462

ALUMINIUM GANTRY CRANE, movable under load
load capacity 1.000 kg with double beam
beam length 5.000 - 8.000 mm

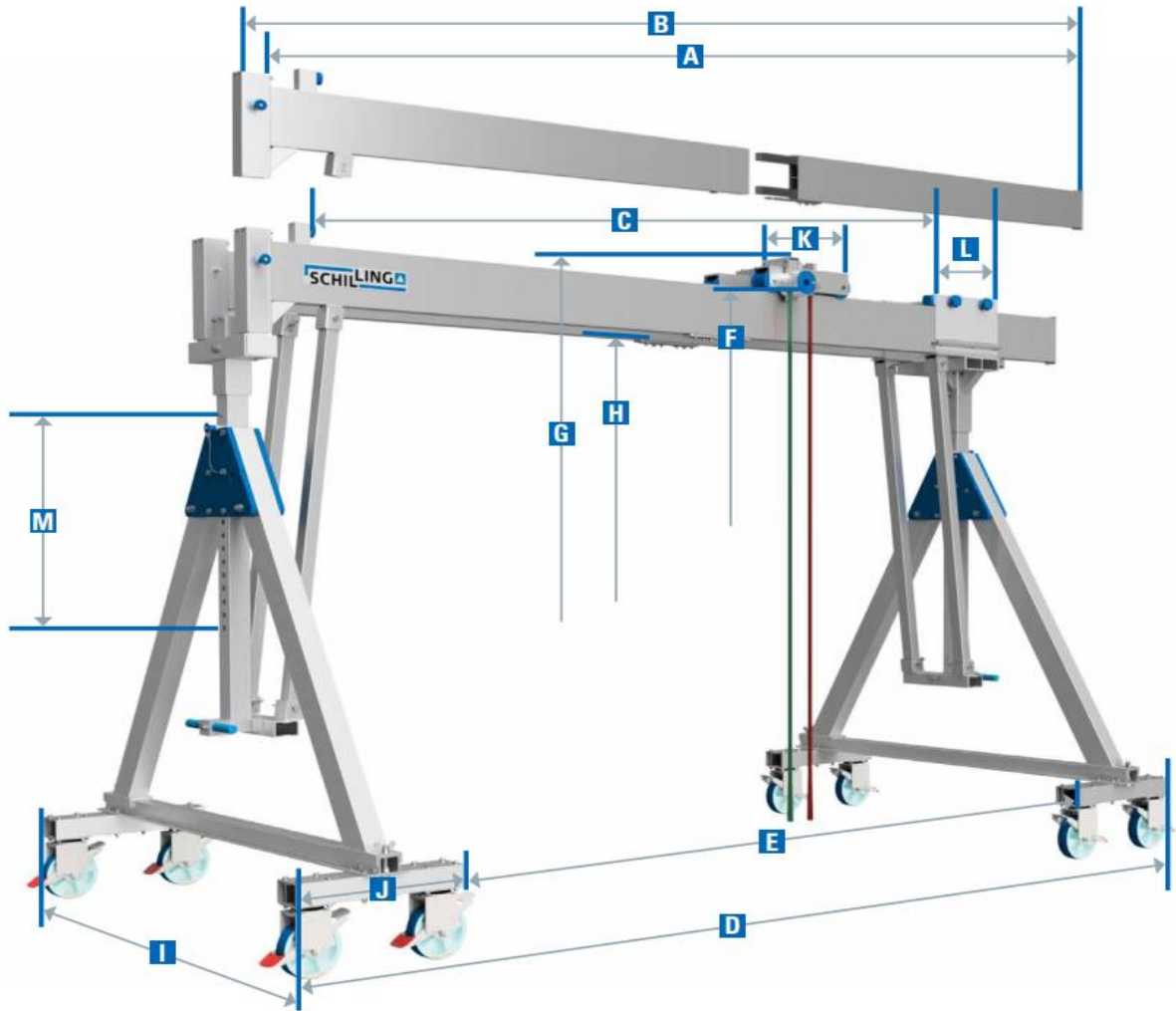

item no.	load capacity	beam length			total width of the crane		suspension point at the bolt of the trolley		total height		lower edge alu beam		lateral stand		park-brake trolley	horizontal adjuster	adjustment range	weight
		clear width	total	usable	outside	inside	min.	max.	min.	max.	min.	max.	width	depth				
	kg	A	B	C	D	E	F		G		H		I	J	K	L	M	kg

SMALL

14401050-10	1000	5000	5016	4158	5482	4290	2135	2485	2235	2585	1868	2218	1488	596	480	421	350	350
14401060-10	1000	6000	6016	5158	6482	5290	2135	2485	2235	2585	1868	2218	1488	596	480	421	350	368
14401070-10	1000	7000	7016	6158	7482	6290	2135	2485	2235	2585	1868	2218	1488	596	480	421	350	385
14401080-10	1000	8000	8016	7158	8482	7290	2135	2485	2235	2585	1868	2218	1488	596	480	421	350	403

MEDIUM

14501050-10	1000	5000	5016	4158	5482	4290	2613	3363	2713	3463	2346	3096	1988	596	480	421	750	383
14501060-10	1000	6000	6016	5158	6482	5290	2613	3363	2713	3463	2346	3096	1988	596	480	421	750	401
14501070-10	1000	7000	7016	6158	7482	6290	2613	3363	2713	3463	2346	3096	1988	596	480	421	750	418
14501080-10	1000	8000	8016	7158	8482	7290	2613	3363	2713	3463	2346	3096	1988	596	480	421	750	435

HIGH

14601050-10	1000	5000	5016	4158	5482	4290	3003	4153	3104	4254	2736	3886	2312	596	480	421	1150	409
14601060-10	1000	6000	6016	5158	6482	5290	3003	4153	3104	4254	2736	3886	2312	596	480	421	1150	427
14601070-10	1000	7000	7016	6158	7482	6290	3003	4153	3104	4254	2736	3886	2312	596	480	421	1150	444
14601080-10	1000	8000	8016	7158	8482	7290	3004	4154	3104	4254	2737	3887	2312	596	480	421	1150	462

ALUMINIUM GANTRY CRANE, movable under load

load capacity 2.000 kg with double beam

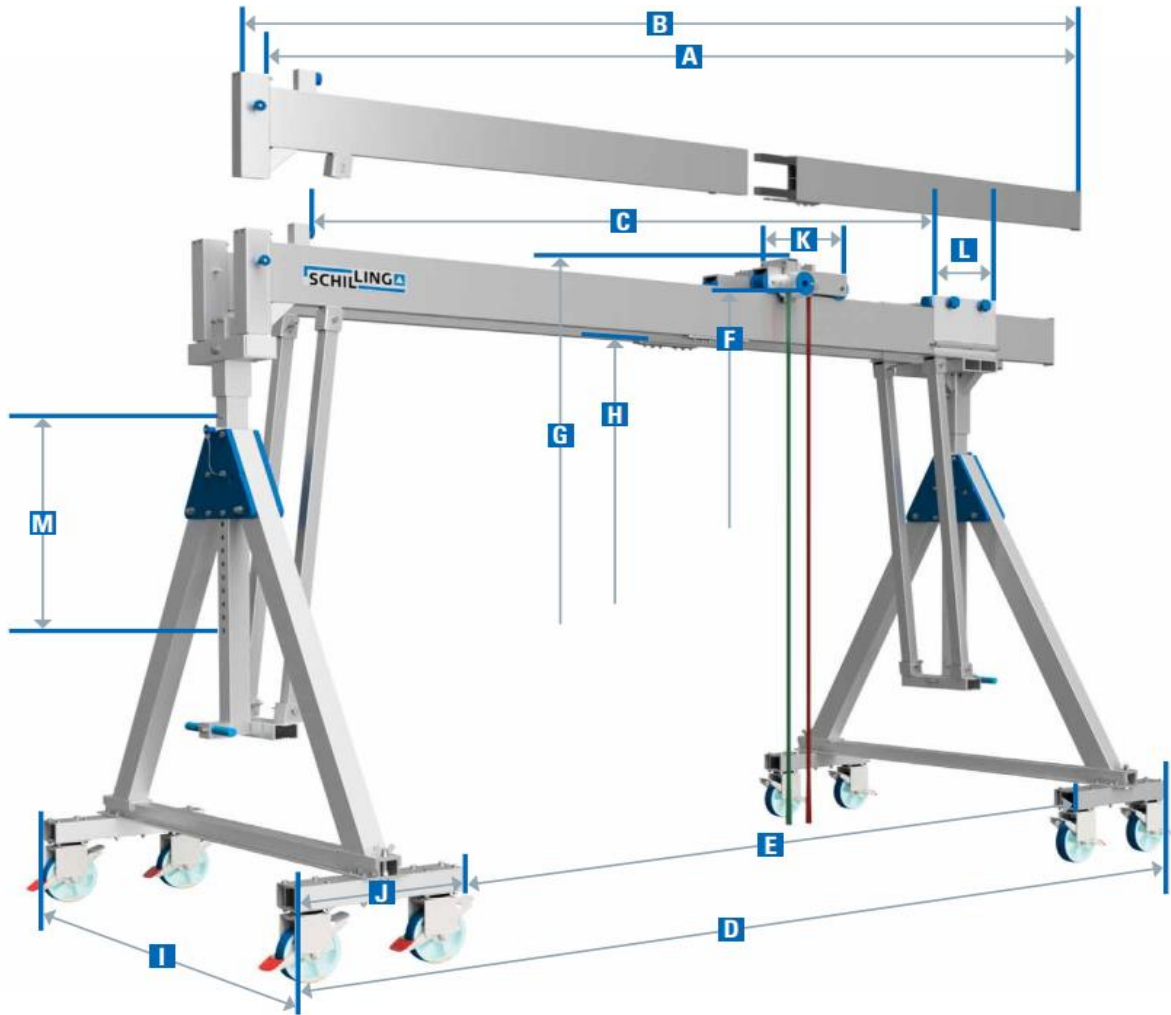

item no.	load capacity	beam length			total width of the crane		suspension point at the bolt of the trolley		total height		lower edge alu beam		lateral stand		park-brake trolley	horizontal adjuster	adjustment range	weight
		clear width	total	usable	outside	inside	min.	max.	min.	max.	min.	max.	width	depth				
	kg	A	B	C	D	E	F		G		H		I	J	K	L	M	kg

SMALL

14402040-10	2000	4000	4016	3158	4482	3290	2135	2485	2235	2585	1868	2218	1488	596	480	421	350	333
14402050-10	2000	5000	5016	4158	5482	4290	2135	2485	2235	2585	1868	2218	1488	596	480	421	350	350
14402060-10	2000	6000	6016	5158	6482	5290	2135	2485	2235	2585	1868	2218	1488	596	480	421	350	368
14402070-10	2000	7000	7016	6158	7482	6290	2135	2485	2235	2585	1868	2218	1488	596	480	421	350	445
14402080-10	2000	8000	8016	7158	8482	7290	2135	2485	2235	2585	1868	2218	1488	596	480	421	350	471

MEDIUM

14502040-10	2000	4000	4016	3158	4482	3290	2613	3363	2713	3463	2346	3096	1988	596	480	421	750	366
14502050-10	2000	5000	5016	4158	5482	4290	2613	3363	2713	3463	2346	3096	1988	596	480	421	750	383
14502060-10	2000	6000	6016	5158	6482	5290	2613	3363	2713	3463	2346	3096	1988	596	480	421	750	401
14502070-10	2000	7000	7016	6158	7482	6290	2613	3363	2713	3463	2346	3096	1988	596	480	421	750	477
14502080-10	2000	8000	8016	7158	8482	7290	2613	3363	2713	3463	2346	3096	1988	596	480	421	750	504

HIGH

14602040-10	2000	4000	4016	3158	4482	3290	3004	4154	3104	4254	2737	3887	2312	596	480	421	1150	392
14602050-10	2000	5000	5016	4158	5482	4290	3004	4154	3104	4254	2737	3887	2312	596	480	421	1150	409
14602060-10	2000	6000	6016	5158	6482	5290	3004	4154	3104	4254	2737	3887	2312	596	480	421	1150	427
14602070-10	2000	7000	7016	6158	7482	6290	3004	4154	3104	4254	2737	3887	2312	596	480	421	1150	504
14602080-10	2000	8000	8016	7158	8482	7290	3004	4154	3104	4254	2737	3887	2312	596	480	421	1150	530

ALUMINIUM GANTRY CRANE, movable under load load capacity 3.000 kg with double beam

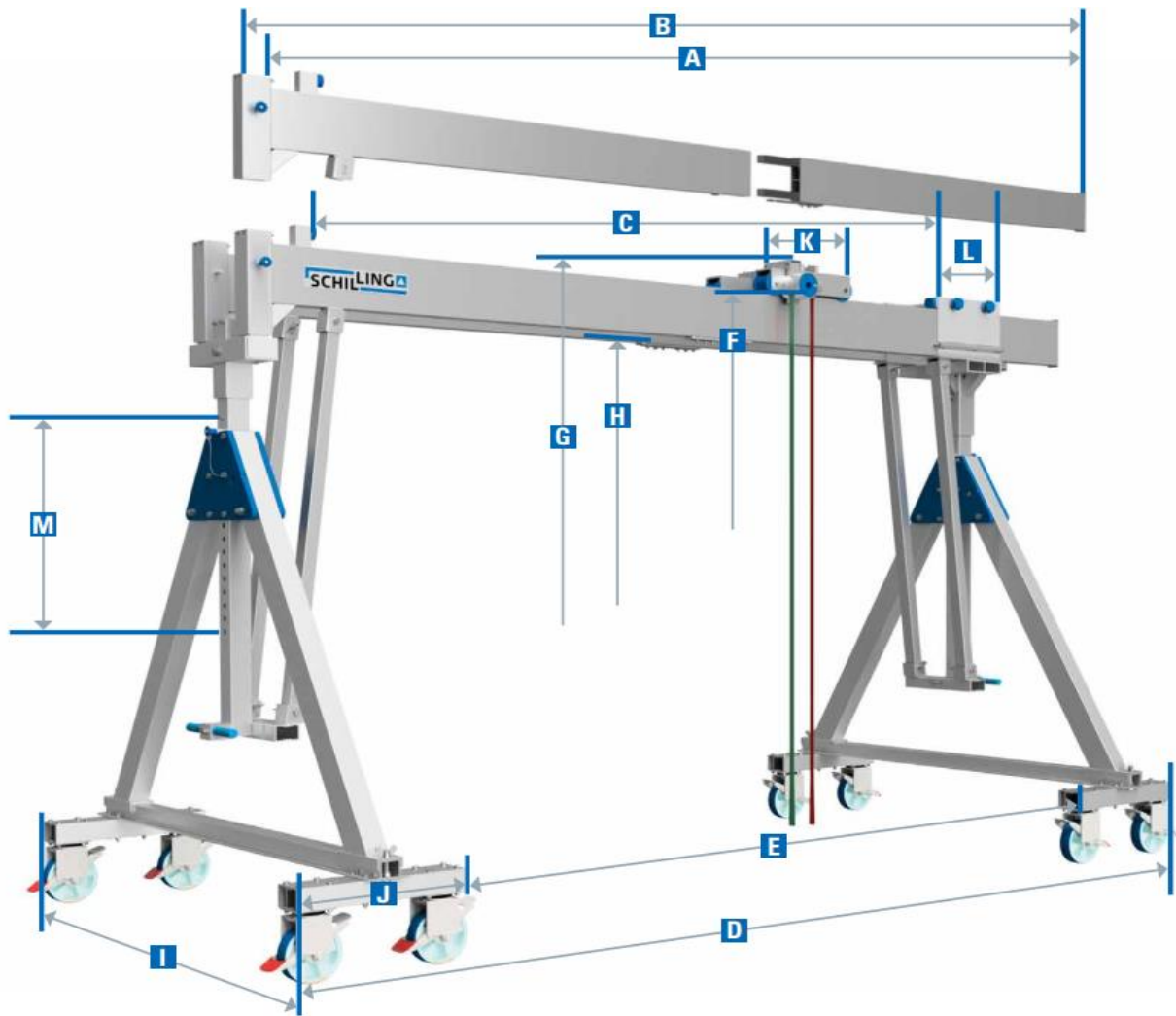

item no.	load capacity	beam length			total width of the crane		suspension point at the bolt of the trolley		total height		lower edge alu beam		lateral stand		park-brake trolley	horizontal adjuster	adjustment range	weight
		clear width	total	usable	outside	inside	min.	max.	min.	max.	min.	max.	width	depth				
	kg	A	B	C	D	E	F		G		H		I	J	K	L	M	kg

SMALL

14403040-10	3000	4000	4016	3158	4482	3290	2135	2485	2235	2585	1868	2218	1488	596	480	421	350	333
14403050-10	3000	5000	5016	4158	5482	4290	2135	2485	2235	2585	1868	2218	1488	596	480	421	350	392
14403060-10	3000	6000	6016	5158	6482	5290	2135	2485	2235	2585	1868	2218	1488	596	480	421	350	418

MEDIUM

14503040-10	3000	4000	4016	3158	4482	3290	2613	3363	2713	3463	2346	3096	1988	596	480	421	750	366
14503050-10	3000	5000	5016	4158	5482	4290	2613	3363	2713	3463	2346	3096	1988	596	480	421	750	425
14503060-10	3000	6000	6016	5158	6482	5290	2613	3363	2713	3463	2346	3096	1988	596	480	421	750	451

HIGH

14603040-10	3000	4000	4016	3158	4482	3290	3004	4154	3104	4254	2737	3887	2312	596	480	421	1150	392
14603050-10	3000	5000	5016	4158	5482	4290	3004	4154	3104	4254	2737	3887	2312	596	480	421	1150	451
14603060-10	3000	6000	6016	5158	6482	5290	3004	4154	3104	4254	2737	3887	2312	596	480	421	1150	477